

LARGE FRUIT AND VEGETABLE PEELING MACHINE

Application

Large vegetable peeling machine is designed as high capacity vegetable peeler. Equipment can process up to 120 products per hour. Machine can be adjusted to different kind of vegetables.

Main benefits

- Minimized surface-to-surface contact area
- Only 1 operator per machine
- Easily washable design
- Food contact compliant materials



Operating principle

The operator inserts the pumpkin into the machine. After that the operator presses the start button and adjusts the peeling speed of the machine with intuitive controller.

As the knife moves up or down the pumpkin rim, a layer of bark is removed. As the peel is peeled, it falls into a box located under the peeler.

When the peeling process is complete, operator presses the button to release the pumpkin and removes it from the peeler.

Processing capacity



LARGE FRUIT AND VEGETABLE PEELING MACHINE
(units/h)

Max weight -12 kg or Ø500mm

Up to 120

*Equipment is adaptable to various size and weight dimensions

See equipment in action



Technical characteristics

Product	Pumpkins and other large vegetables
Processing capacity	Up to 120 products per hour
Equipment dimension (LxWxH)	1040x1016x2223 (mm)
Number of operators on the machine	1
Key features	Adaptable, effective, easy to use

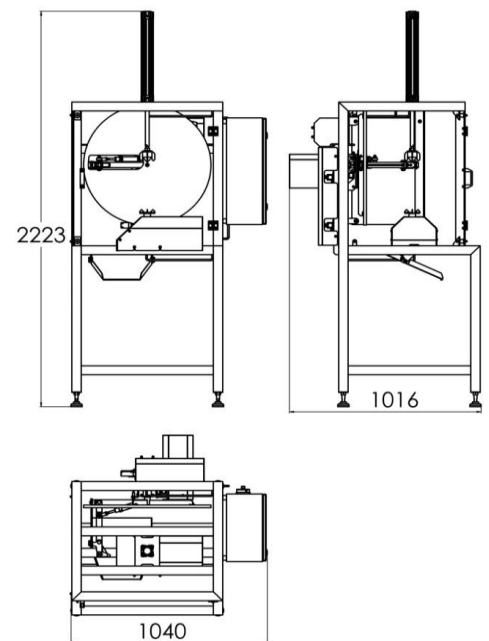

For more processing solutions



Autonobbing line

Reduce your cost of nobbing!



Drum-type nobbing line

Process small fish into quality product!



Water defrosting line

Use efficient defrosting for your products!

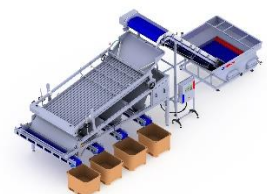

Roller grading line

Grading - a must for industrial processing of fish!